

TROPICAL TURFGRASS LAWN CONSTRUCTION

Kenneth Marcum 08/2010

PROPER construction and establishment are essential for good lawns. Shortcuts taken during this stage will cause numerous problems in the future, including poor drainage and waterlogging, soil compaction, fertility or pH issues, weeds, and poor turf quality. Prior to construction, decisions must be made based on the proposed use of the turf. General lawn use (low maintenance turf) will have different construction requirements than event or sports lawn use (high maintenance turf). General lawn use will usually not require the expensive subsurface drainage system that event/sports lawns do. However, adequate drainage is still critical, requiring good surface grading and rootzone material. Proper turfgrass species selection, based on intended use, is also important.

I. GENERAL LAWN CONSTRUCTION

a) ROOTZONE MATERIAL

Rootzone material must provide good drainage and resist compaction under moderate foot traffic. Singapore soils, generally tropical clays, do not offer adequate drainage, and are susceptible to compaction, resulting in waterlogging and poor turf quality. Sand-based rootzones are a solution for event/sports lawns, but require high maintenance, including irrigation and more frequent fertilisation, and therefore are not a good choice for general lawns.

For general lawn construction, a rootzone of CUGE Approved Soil Mix (ASM) is recommended, consisting of clay loam soil, compost, and coarse sand. Compost must be mature, with a stable C:N ratio, otherwise nutrient deficiencies will occur. Sand should be of uniform coarse texture, with at least 70% of particles 0.5 – 3.0 mm in diameter. A ratio of 3 parts soil, 2 parts compost, and 1 part sand may be used. The compost and sand provide improved drainage and nutrient availability. ASM must be thoroughly mixed offsite, prior to installation (Fig. 1). Mixing onsite results in nonuniform ASM, causing drainage problems. Rootzone (ASM) depth of 30 cm is recommended. If budget is a constraint, 20 cm may be used, though drainage problems may result. If existing onsite topsoil is adequate, this may be removed for use in ASM. Prior to use, existing turf sod, weeds, woody debris, and large stones must be removed. If onsite topsoil is not used in ASM, existing turf sod and weeds must still be removed. Leaving them will result in drainage, fertility, and disease problems.



Figure 1. Mixing ASM offsite results in a uniform mix, avoiding subsequent drainage problems.

ASM should be tested for fertility and pH, prior to installation if possible. Testing should include all major nutrients, cation exchange capacity, and pH. If pH is outside of the range of 5.5-7, it should be adjusted (see CUGE Research Technical Note *Tropical Turfgrass Fertilisation*, serial no. 1113-10). Amendments for pH and phosphorous are best when evenly mixed throughout the rootzone layer, as they are immobile in soils. In contrast, starter fertiliser is usually mixed into the top layer the rootzone just prior to planting.

b) GRADING AND PREPARATION FOR PLANTING

Surface grading is critical to provide adequate drainage, especially when subsurface drains are not present. Ideally, 2% or more surface grade (slope) is necessary, with no more than 25 m run to a constructed surface drain. Both ASM rootzone and subsurface layer must be graded identically (i.e. follow the same relief); otherwise wet and dry areas will occur. To do this, install temporary depth marker stakes prior to pouring ASM rootzone layer. Always slope away from existing buildings. Protect existing trees from equipment injury by wrapping trunks.

Following ASM rootzone installation and grading, roll lightly to settle, and adjust final grade. Then apply starter fertiliser having an N-P-K ratio of 1-2-1 or 1-1-1, and rake into the top 3 cm. Apply sufficient fertiliser to provide 4 kg N (nitrogen)/1000 square metres. The area is now ready for planting (see CUGE Research Technical Notes *Tropical Turfgrass Planting*, serial no. 1113-02). For low maintenance, general use lawns, a *Zoysia* species or *Axonopus compressus* (cowgrass) may be used. Alternately, *Stenotaphrum secundatum* (St. Augustinegrass) or *Axonopus* sp. 'Pearlgrass' are good choices when tree canopy shade is present. 'Pearlgrass' is a low maintenance option, requiring less mowing and fertiliser than other species, however it has no traffic tolerance and is expensive to plant. Select the turfgrass based on intended use and maintenance level.

¹ Fertiliser rates given are in actual N (nitrogen). For example, if the required rate is 4 kg N/1000 square/metres, and you are using 15-15-15 fertiliser, then the amount of fertiliser required would be: $4 \text{ kg N} \div (15\% \text{ N}) = 26.6 \text{ kg fertiliser}$.

II. EVENT AND SPORTS LAWN CONSTRUCTION

a) ROOTZONE MATERIAL

For high use lawns, a sand-based rootzone, and a subsoil drainage system may be required to provide adequate drainage, and resist compaction due to heavy traffic. For event and sports lawn construction, a sand-based root zone is recommended, consisting of a minimum of 75% sand. Sand should be of uniform coarse texture, with at least 70% of particles 0.5 – 3.0 mm in diameter. The balance of the root zone mix should be either compost, or compost plus soil, depending on anticipated useage. In very high foot traffic situations (sports fields), a root zone comprised solely of sand and compost may be used. Compost provides improved water holding capacity and nutrient availability. Compost must be mature, with a stable C:N ratio, otherwise nutrient deficiencies will occur. Root zone components must be thoroughly mixed offsite, prior to installation (Fig. 1). Mixing onsite results in nonuniformity, causing drainage problems. Root zone depth of 30 cm is required.

b) SUBSURFACE GRADING AND INSTALLING DRAINS

Establish subgrade to mirror proposed final surface grade. A slope grade of 2% or more should be present to provide surface drainage. Always slope away from existing building foundations. Remove large rocks, undecomposed wood, and existing turf sod during subgrading, as these will cause drainage and disease problems. When subgrading is complete, compact surface by rolling.

Install subsurface drains in either a herringbone or gridiron pattern (Fig. 2). Either corrugated plastic pipe (most common) or PVC pipe may be used, with drain perforations facing down. Primary drain pipes should be 150 mm diameter, installed to follow the maximim line of fall. Lateral pipes are 100 mm diameter, spaced approximately 5 metres apart, with distance along a lateral to a primary drain no more than 5 metres. Outlet of primary pipes must be adequate to accept anticipated drainage flow during high rainfall conditions. Drain trenches should be 300 mm deep x 300 mm wide.

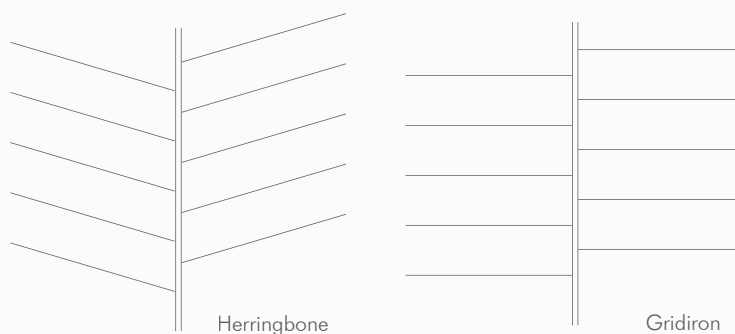

Figure 2. Herringbone and gridiron subsurface drain patterns

Figure 2. Herringbone and gridiron subsurface drain patterns

c) SUBSURFACE DRAINAGE – EVENT/SPORTS LAWNS

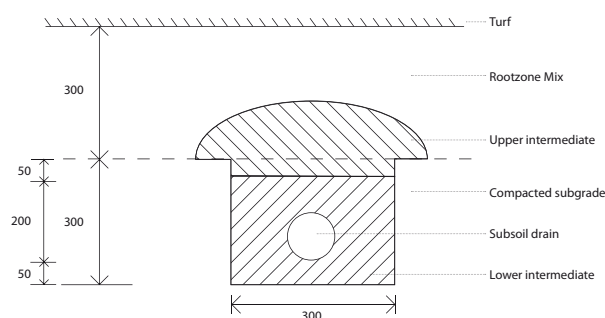

Figure 3. Subsurface drainage for normal event/sports lawns.

Drainage system for normal event/sports lawns consists of 3 layers: drainage zone, intermediate zone, and root zone (Fig. 3). Materials should be uniform in particle size, and stable, i.e. coral materials, sandstone, etc. should not be used. Particle size distribution of drainage zone should be at least 75% within 4 – 9 mm, and intermediate zone at least 75% within 1 – 4 mm diameter. Line trenches with a 50 mm layer of drainage zone material before laying pipes. Pipe drain holes should face downward; do not wrap pipes with geotextile. Continue filling trenches to

within 50 mm of top with drainage zone material. Moisten drainage zone material, then fill remainder of trench with intermediate zone material, spilling over onto subgrade base. Install root zone, of uniform thickness throughout field, mirroring subgrade. To achieve this, insert stakes marked at 300 mm in a grid pattern across subgrade. Root zone material should be 75% coarse sand, 25% soil-compost blend (see above). Mix root zone offsite prior to installation (Fig. 1).

d) SUBSURFACE DRAINAGE – HIGH USE EVENT/SPORTS LAWNS

Drainage system for high use event/sports lawns consists of 4 layers: drainage zone, lower intermediate zone, upper intermediate zone, and root zone (Fig. 4). Layer material should be uniform in particle size, and stable, i.e. coral materials, sandstone, etc. should not be used. Particle size distribution of drainage zone should be at least 75% within 8 – 14 mm, lower intermediate zone at least 75% within 4 – 10 mm, and upper intermediate zone at least 75% within 1 – 5 mm diameter.

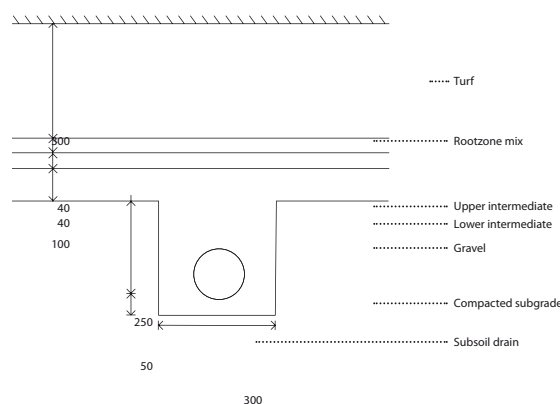

Figure 4. Subsurface drainage for high use event/sports lawns.

Install marked stakes across subgrade in a grid pattern, with depth of subsequent layers marked (Fig. 5). This will allow for grading of layers to exactly mirror one another. Failure to do so will result in wet and dry areas. Line trenches with a 50 mm layer of drainage zone material before laying pipes. Pipe drain holes should face downward; do not wrap pipes with geotextile. Continue filling trenches to apply a drainage layer 100 mm deep atop subgrade. Moisten drainage zone material, then install 40 mm depth lower intermediate zone material, followed by moistening and installation of 40 mm depth upper intermediate layer. Install root zone 300 mm deep. Root zone material should be 75% coarse sand, 25% compost (see above). Mix root zone offsite prior to installation (Fig. 1).



Figure 5. Marker stakes used to mirror layers in grading process.

e) FINAL GRADING AND PREPARATION FOR PLANTING

Following rootzone installation and grading, roll lightly to settle, and adjust final grade. Then apply starter fertiliser having an N-P-K ratio of 1-2-1 or 1-1-1, and rake into the top 3 cm. Apply sufficient fertiliser to provide 4 kg N (nitrogen)/1000 square metres¹. The area is now ready for planting (see CUGE Research Technical Notes *Tropical Turfgrass Planting*, serial no. 1113-02). For normal event/sports lawns, a *Zoysia* species, *Digitaria didactyla* (Serangoongrass), or *Cynodon dactylon/transvaalensis* (bermudagrass/hybrid bermudagrass); *Axonopus compressus* (cowgrass) is not recommended. Use *Cynodon* species only in full sun settings. For high use event/sports lawns, a *Zoysia* species, *Cynodon dactylon/transvaalensis* (bermudagrass/hybrid bermudagrass), or *Paspalum vaginatum* (seashore paspalum) may be used. Proper lawn construction and turfgrass selection will minimise future problems, reduce maintenance costs, and provide superior quality turfgrass for high use event and sports lawns.